

REVISIONS

REV	DESCRIPTION	DATE	APPR
A	ORIGINAL RELEASE	08/31/20	DNS

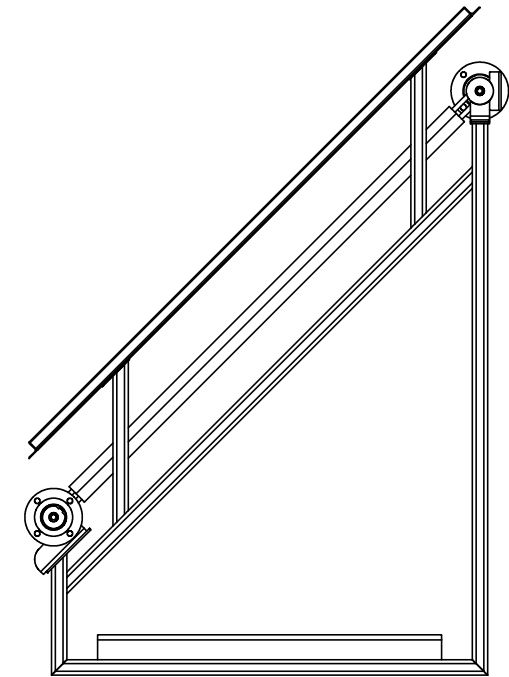
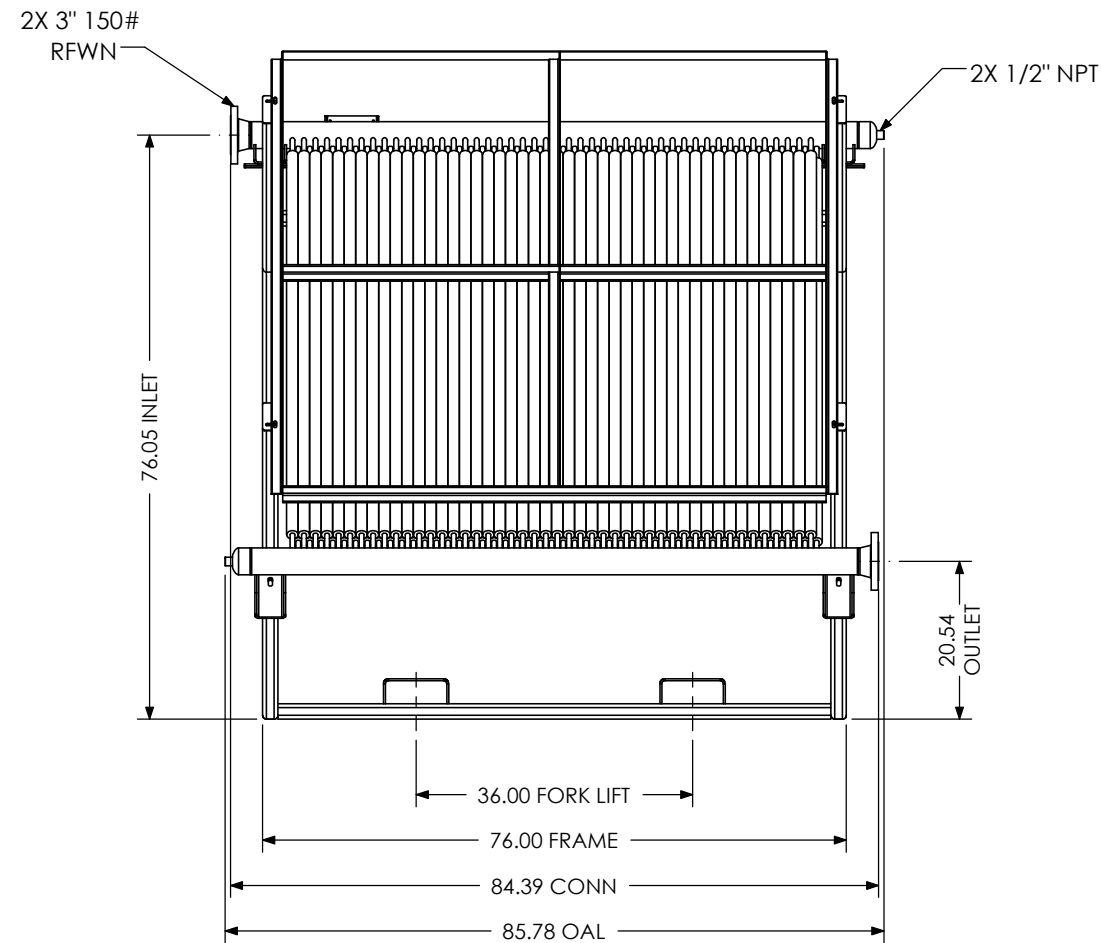
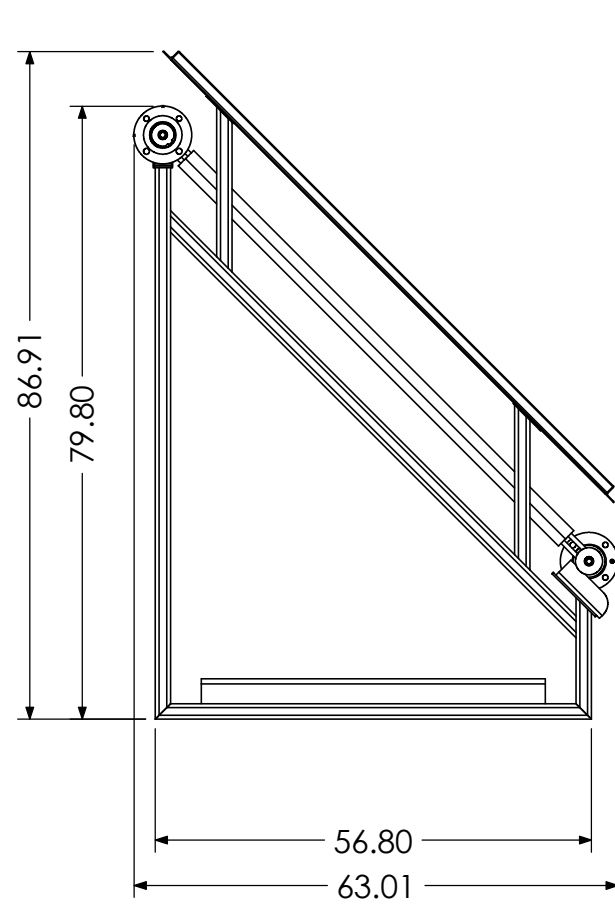

Approved By:
 Dana Bardeaux
 9/4/2020

BOM Table				
ITEM NO	QTY	PART NO	DESCRIPTION	MATERIAL
1	1	300S-001	FRAME ASSEMBLY	C STEEL, FULLY WELDED
2	1	300S-027-320015	ASC SERIES COIL W/ TRANS	TUBES: 316/L SA249 / FINS: ALUM
3	1	300S-029	PROTECTIVE GUARD	1.5" X 1.5" X 0.125" CS ANGLE W/ EXP MTL, GALV

DESIGN INFORMATION			
DESCRIPTION	DESIGN TEMPERATURE	DESIGN PRESSURE	TEST PRESSURE (PNEUMATIC)
300S-027-320015	400 °F	25 PSIG	27.5 PSIG

UNLESS OTHERWISE SPECIFIED:		NAME	DATE	EXACT EXCHANGER INCORPORATED PO BOX 795187 DALLAS, TX 75379-5187 (O) 972-466-1999 or 800-443-9228 (F) 972-466-1878
DIMENSIONS ARE IN INCHES	DRAWN	HDE	08/31/20	
TOLERANCES: ANGULAR/BEND ± 1° TWO PLACE DECIMAL ±0.125 THREE PLACE DECIMAL ±0.063	ENG APPR.	MNS	08/31/20	
PROPRIETARY AND CONFIDENTIAL	MFG APPR.	DNS	08/31/20	TITLE: APPROVAL DRAWING
THE INFORMATION CONTAINED IN THIS DRAWING IS THE SOLE PROPERTY OF EXACT EXCHANGER. ANY REPRODUCTION IN PART OR AS A WHOLE WITHOUT THE WRITTEN PERMISSION OF EXACT EXCHANGER IS PROHIBITED.	COMMENTS:		DO NOT SCALE DRAWING	SIZE B DWG. NO. SL300-320015 REV A
		SCALE: 1:25	EST WEIGHT: 948	SHEET 1 OF 1